



(72) DELLI-GATTI, FRANK A., JR., US

(71) COALTEX, INC., US

(51) Int.Cl.<sup>6</sup> E21C 27/24, E21C 35/24, E21C 41/16

(30) 1997/02/11 (08/797,734) US

(54) **EXPLOITATION D'UNE COUCHE TRES MINCE DE CHARBON**

(54) **MINING ULTRA THIN COAL SEAMS**

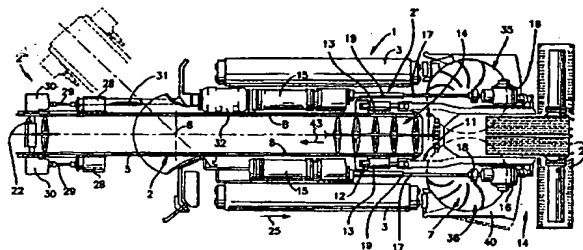

(57) L'invention concerne une machine minière fonctionnant en continu (4) et destinée à exploiter des couches très minces de charbon (54), par exemple des couches dont l'épaisseur est d'environ 60 centimètres ou moins. Un châssis (25), soutenu par des chenilles de roulement (53) présente un tête de coupe mécanique (14), à axe sensiblement horizontal, montée sur l'avant du châssis, ainsi qu'une bande de transport (4) s'étendant à partir d'une tête rassembleuse (7) vers l'arrière du châssis. Cette bande de transport comprend une chaîne (9) entraînée par au moins un moteur (28) monté à proximité de l'arrière du châssis et destiné à entraîner un pignon à chaîne. La tête rassembleuse comprend une paire de disques contrarotatifs (35, 36) présentant des pales verticales (37) et un tablier (40) formant un angle maximum d'environ 10° par rapport à la dimension d'élongation (25) du châssis. On a monté une roue dentée libre et de petit diamètre (23), destinée à la chaîne transporteuse, sous le tablier, ainsi qu'une roue d'entraînement dentée et de petit diamètre (21), destinée à la chaîne de coupe de la tête de coupe. On commande cette machine, de façon qu'elle reste dans une couche de charbon à couper, à l'aide d'une première caméra vidéo en couleurs (60) laquelle balaye le plafond (51) de la galerie creusée par la machine minière, et d'une seconde caméra vidéo en couleurs (61), laquelle balaye le sol (41). On peut utiliser cette machine dans un procédé d'exploitation d'une mine dans lequel, lors du retrait de la machine après formation d'une galerie principale (42) dont la longueur est d'environ 90 à 180 mètres, on forme un certain nombre de galeries de côté (60), chacune à peu près de la longueur de la machine.

(57) A continuous mining machine (4) is provided for mining ultra thin coal seams (54), e.g. seams having a thickness of about 60 centimeters or less. A chassis (25) supported by crawler tracks (53) has a substantially horizontal axis powered cutter head (14) mounted to its front and a conveyor (4) extending from a gathering head (7) toward the rear of the chassis. The conveyor includes a conveyor chain (9) driven by at least one motor (28) near the rear of the chassis for driving a sprocket. The gathering head includes a pair of counter-rotating discs (35, 36) with upstanding vanes (37) and a deck (40) having a maximum angle of about 10° with respect to the dimension of elongation (25) of the chassis. A small diameter idler sprocket (23) for the conveyor chain is mounted beneath the deck, and a small diameter drive sprocket (21) is provided for the cutting chain of the cutting head. The mining machine is controlled to keep it within a coal seam to be cut by using a first color video camera (60) scanning the ceiling (51) of the bore cut by the miner, and a second color video camera (61) scanning the floor (41). The mining machine may be used in a method of mining in which, after formation of a main bore (42) of about 90-180 meters long, during withdrawal the machine forms a number of angled bores (60) each roughly as long as the length of the machine.



PCT

WORLD INTELLECTUAL PROPERTY ORGANIZATION  
International Bureau

INTERNATIONAL APPLICATION PUBLISHED UNDER THE PATENT COOPERATION TREATY (PCT)

(51) International Patent Classification <sup>6</sup> : E21C 27/24, 35/24, 41/16	A1	(11) International Publication Number: <b>WO 98/3513</b> (43) International Publication Date: 13 August 1998 (13.08.98)
<p>(21) International Application Number: PCT/US98/00155</p> <p>(22) International Filing Date: 13 January 1998 (13.01.98)</p> <p>(30) Priority Data: 08/797,734 11 February 1997 (11.02.97) US</p> <p>(71) Applicant: COALTEX, INC. [US/US]; P.O. Box 1085, Beckley, WV 25801 (US).</p> <p>(72) Inventor: DELLI-GATTI, Frank, A., Jr.; Coaltex, Inc., P.O. Box 1085, Beckley, WV 25801 (US).</p> <p>(74) Agent: VANDERHYE, Robert, A.; Nixon &amp; Vanderhye P.C., 8th floor, 1100 North Glebe Road, Arlington, VA 22201-4714 (US).</p>	<p>(81) Designated States: AL, AM, AT, AU, AZ, BA, BB, BG, BI, BY, CA, CH, CN, CU, CZ, DE, DK, EE, ES, FI, GB, GI, GH, GM, GW, HU, ID, IL, IS, JP, KE, KG, KP, KR, KZ, LC, LK, LR, LS, LT, LU, LV, MD, MG, MK, MN, MW, MX, NO, NZ, PL, PT, RO, RU, SD, SE, SG, SI, SK, SL, T, TM, TR, TT, UA, UG, UZ, VN, YU, ZW, ARIPO pater (GH, GM, KE, LS, MW, SD, SZ, UG, ZW), Eurasian pater (AM, AZ, BY, KG, KZ, MD, RU, TJ, TM), European pater (AT, BE, CH, DE, DK, ES, FI, FR, GB, GR, IE, IT, LI, MC, NL, PT, SE), OAPI patent (BF, BJ, CF, CG, CI, CN, GA, GN, ML, MR, NE, SN, TD, TG).</p> <p>Published With international search report.</p>	

(54) Title: MINING ULTRA THIN COAL SEAMS

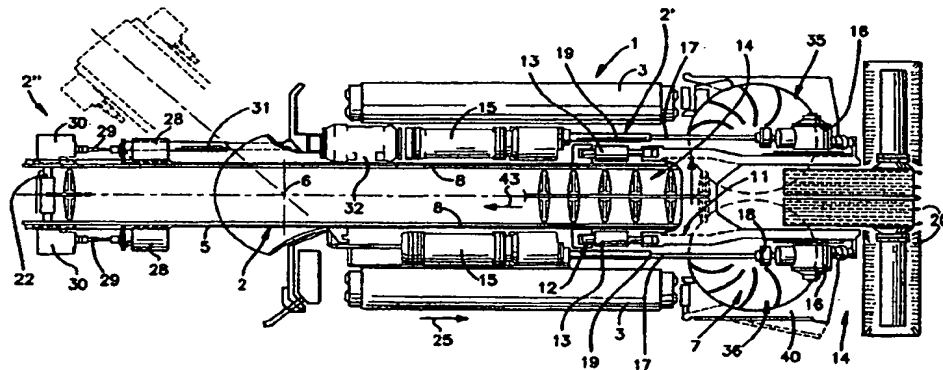

(57) Abstract

A continuous mining machine (4) is provided for mining ultra thin coal seams (54), e.g. seams having a thickness of about 6 centimeters or less. A chassis (25) supported by crawler tracks (53) has a substantially horizontal axis powered cutter head (14) mounted at its front and a conveyor (4) extending from a gathering head (7) toward the rear of the chassis. The conveyor includes a conveyor chain (9) driven by at least one motor (28) near the rear of the chassis for driving a sprocket. The gathering head includes a pair of counter-rotating discs (35, 36) with upstanding vanes (37) and a deck (40) having a maximum angle of about 10° with respect to the dimension of elongation (25) of the chassis. A small diameter idler sprocket (23) for the conveyor chain is mounted beneath the deck, and a small diameter drive sprocket (21) is provided for the cutting chain of the cutting head. The mining machine is controlled to keep it within a coal seam to be cut by using a first color video camera (60) scanning the ceiling (51) of the bore cut by the miner, and a second color video camera (61) scanning the floor (41). The mining machine may be used in a method of mining in which, after formation of a main bore (42) of about 90-180 meters long, during withdrawal the machine forms a number of angled bores (60) each roughly as long as the length of the machine

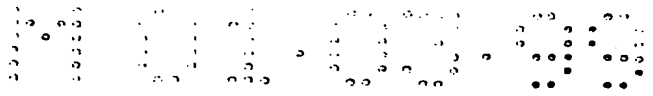

**MINING ULTRA THIN COAL SEAMS**

**BACKGROUND AND SUMMARY OF THE INVENTION**

There are literally millions of tons of coal in the United States alone that are found in thin coal seams (having a thickness of about  
5 1.2 meters (four feet or less), and ultra thin coal seams (having a thickness of around .6 meters (two feet) or less). Utilizing conventional equipment and techniques the vast majority of this coal is unrecoverable. While auger miners can be successful in thin and ultra thin seams, augers are very limited in the depth of bore they can form  
10 (typically limited to about 45.75 meters (150 feet)), and because of the circular bores that they form leave a great deal of coal between penetrations. It was for that reason that the continuous mining machine in U.S. patent 3,874,735 was developed. That mining machine, marketed in commercial form by Lee-Norse under the trade  
15 designations CM245 and CM285, is the shortest continuous miner (non-auger) believed to ever have been commercialized. For example the CM245 has a chassis height of only about .6 meters (24 inches), and can be used in coal seams as thin as .76 meters (30 inches). While that machine is a significant advance in the art and has great  
20 functionality for a number of thin coal seams, its design makes it -- as a practical matter -- impossible to reduce its size further to allow it to be used in ultra thin coal seams.

According to the present invention a continuous mining machine is provided which uses the same basic concepts of the CM245 and  
25 285, such as shown in U.S. patent 3,874,735, but makes a few changes to the construction that allows it to be made even shorter, so that it can effectively mine coal seams having a thickness of about 24 inches or less. The continuous mining machine according to the invention has a chassis height of only about 48-50 cm (19 or 20

inches), and a maximum cutter diameter of about 56 cm (22 inches) (preferably 53 cm (21 inches)), yet it can effectively mine coal in seams. The mining machine according to the invention is also preferably controlled utilizing color cameras which scan at least the ceiling and the floor of a bore being formed to ensure that coal is primarily being cut rather than surrounding rock. Also according to the present invention a continuous mining machine can be utilized in an unusual technique for recovering as much coal as possible from a single complete penetration by forming angled bores into the side walls of the main bore as the mining machine is being withdrawn. Utilizing the mining machine according to the invention rather than being restricted to a bore length of about 49 meters (150 feet), such as is conventional with augers, bores from 90-180 meters (300 to 600 feet) may be constructed, with additional coal recovered during withdrawal.

According to one aspect of the present invention a continuous mining machine is provided comprising the following components: A chassis supported by crawler tracks, and having a front and a rear and elongated in a first dimension between the front and the rear. A substantially horizontal axis powered cutter head mounted to the front of the chassis. A conveyor mounted to the chassis and including an endless conveyor chain. The chain connected to first and second sprockets, the first sprocket mounted for rotation about a first shaft adjacent the rear of the chassis, and the second sprocket mounted for rotation about a second shaft adjacent the front of the chassis but between the first sprocket and the cutter head. The first and second shafts rotatable about axes generally perpendicular to the first dimension. And, at least one motor mounted adjacent the rear of the chassis for driving the first shaft to thereby drive the first sprocket and the conveyor.

The second shaft preferably comprises an idler shaft, and the machine further preferably includes a gathering head mounted adjacent the front of the chassis and below the cutter head and at least partly to the rear of the cutter head, for gathering material cut by the cutter head and moving the cut material to the conveyor. The gathering head preferably comprises a pair of counter-rotating discs with upstanding vanes, and an angled deck substantially coplanar with the discs; and wherein the second shaft has first and second transmission elements connected thereto, the first and second transmission elements operatively connected to the discs for effecting counter-rotation driving thereof. The angled deck, during normal operation, makes a maximum angle of about  $10^\circ$  with respect to the dimension of elongation of the chassis. The chassis has a maximum height of about 50 cm (20 inches) (e.g. a height of about 48 cm (19 inches)) and the cutter head has a maximum effective diameter of about 56 cm (22 inches) (e.g. about 53 cm (21 inches)), as further explained below. The second sprocket has a maximum diameter of about eight inches and is mounted beneath the deck, and preferably includes four tapered teeth. A plurality of cross bars are preferably connected to the chain for moving conveyed material (typically coal) from the gathering heads to the rear of the chassis.

The cutter head drive is also preferably specially constructed so that it is assured that a minimum height can be achieved. For example the drive sprocket or sprockets (typically two are provided adjacent opposite ends of a shaft) preferably comprises a five tooth sprocket having a maximum diameter of about 19 cm (7.5 inches) (e. g. about 17.8 cm (7.02 inches)) on about a 10 cm (four inch) diameter shaft, with the cutting head effective diameter (the trace of the cutting chain bits) at that area of about 41 cm (16 inches) or less (e. g. about 39 cm (15.3 inches)). The driven sprocket at the front of the head, where the

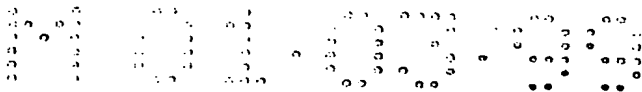

actual cutting is done, may comprise a ten tooth sprocket with a maximum diameter of about 36 cm (14 inches) (e. g. about 34 cm (13.35 inches)), and with the cutting head effective diameter a maximum of about 56 cm (twenty two inches) (e. g. about 53 cm (21.04 inches)). The cutting chain may comprise a conventional cutting chain having alternating connector and cutting bit links, e. g. Number 73473 clearance chain available from The Cincinnati Mine Machinery Co. of Cincinnati, Ohio.

The mining machine further comprises a first color video camera mounted on the chassis or the cutter head in a position to scan material being cut above the cutter head and utilizable to determine the color thereof, the first video camera connected to a monitor to the rear of the chassis. The mining machine forms a floor during operation, and preferably further comprises a second color video camera mounted to the chassis or the cutter head in a position to scan the floor cut by the mining machine and utilizable to determine the color thereof, the second video camera connected to the monitor.

The second shaft typically has first and second transmission elements (preferably gears) connected thereto, the first and second transmission elements operatively connected (through other gears in the preferred embodiment) to the discs for effecting counter rotation driving thereof.

According to another aspect of the present invention a continuous mining machine is provided comprising the following components: A chassis supported by crawler tracks, and having a front and a rear and elongated in a first dimension between the front and the rear. A powered cutter head mounted to the front of the chassis. A conveyor mounted to the chassis and including an endless conveyor chain. The chain connected to first and second sprockets, the first sprocket mounted for rotation about a first shaft adjacent the

rear of the chassis, and the second sprocket mounted for rotation about a second shaft adjacent the front of the chassis but between the first sprocket and the cutter head. The first and second shafts rotatable about axes generally perpendicular to the first dimension. At least one motor for driving one of the first and second shafts to thereby drive one of the sprockets and the conveyor. A gathering head mounted adjacent the front of the chassis and below the cutter head and at least partly to the rear of the cutter head, for gathering material cut by the cutter head and moving the cut material to the conveyor, the gathering head comprises a pair of counter-rotating discs with upstanding vanes, and an angled deck substantially coplanar with the disc. The second shaft having first and second transmission elements connected thereto, the first and second transmission elements operatively connected to the discs for effecting counter-rotation driving thereof. The angled deck during normal operation making a maximum angle of about  $10^\circ$  with respect to the dimension of elongation of the chassis. And, the chassis having a maximum height of about 50 cm (twenty inches), and the cutter head having a maximum diameter of about 56 cm (twenty two inches). The second sprocket has a maximum diameter of about (eight inches) 20 cm and is mounted beneath the deck.

The invention also relates to a method of mining coal in thin seams. The mining machine described above is particularly suited for practicing the method of the invention, although other mining machines also may be utilized. According to the method of the present invention seams having an average thickness of less than 1.2 meters (four feet) may be mined utilizing a continuous mining machine having a chassis mounted by crawler tracks, a cutter head at the front of the chassis, an articulated rear end, a first conveyor for conveying cut coal from the cutter head to the rear of the chassis, and a second conveyor

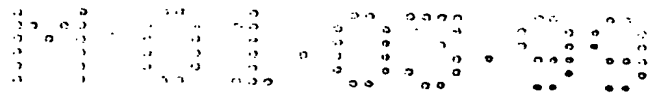

operatively associated with the rear end to convey coal from a bore toward a mouth of the bore, the continuous miner having a predetermined length from the cutter head to the rear of the chassis. The method preferably comprises the steps of: (a) Forming a main mine bore, having first and second side walls, a roof, and a floor, by powering the crawler tracks and cutter head to move the continuous miner through the mine mouth into the coal seam a depth of more than 45 meters (150 feet) in a first direction, while cutting coal and conveying the coal toward the mouth using the first and second conveyors. (b) After the practice of step (a), retracting the continuous miner a distance of greater than about 3 meters (ten feet). And, (c) after the practice of step (b), forming a secondary mine bore by powering the crawler tracks and the cutter head to move the continuous miner into the coal seam through the main mine bore side walls at an angle of greater than about 20° and less than about 80° (e.g. between about 30-50°) to the first direction for a distance roughly equal to the predetermined length of the miner (e.g. between about 6-12 meters (20-40 feet)), while cutting coal and conveying cut coal toward the mouth using the first and second conveyors.

The method also preferably comprises the further step (d) of repeating steps (b) and (c) at least once during the practice thereof. Step (c) is typically practiced by moving the mining machine into contact with the first side wall of the main bore, and step (d) is practiced after (c) by moving the miner into contact with the second wall of the main bore. Step (d) is also practiced a plurality of times, alternating between moving the miner into contact with the first side wall and the second side wall of the main bore. The method may be practiced in coal seams having an average thickness of about three feet or less, and even in ultra thin coal seams having an average thickness of about .6 meters (two feet) or less.



Preferably during the practice of step (a) the miner is remotely controlled by a human operator, and the miner has at least a first color video camera mounted thereon; and the method preferably comprises the further step (d) of scanning the roof of the bore adjacent the cutter head to determine the color thereof, and then the human operator  
5 adjusting, if necessary, the position of the cutter head and the vertical orientation of the miner in response to that scanning. The miner typically also has a second color video camera mounted thereon, and there is the further step (e) of scanning the floor of the bore with the  
10 second video camera to determine the color thereof, and then the human operator adjusting, if necessary, the position of the cutter head and the vertical orientation of the miner in response to that scanning.

Step (a) is typically practiced to penetrate the coal seam a distance of over 45 meters (150 feet), typically between about 90-150  
15 meters (300-600 feet). The mining machine utilized in the practice of the method of the invention typically has a length of about 7.5-9 meters (25 to 30 feet) (e.g. about 8.5 (28 feet)), and in any event steps (c) and (d) are typically practiced to penetrate the coal seam a distance of between about 6-12 meters (20-40 feet) in forming each  
20 secondary bore.

It is the primary object of the present invention to provide a continuous miner, and mining method, that can mine ultra low thickness coal seams to a depth of more than 45 meters (150 feet) without putting a human operator at risk. This and other objects of the  
25 invention will become clear from an inspection of the detailed description of the invention and from the appended claims.

### BRIEF DESCRIPTION OF THE DRAWINGS

FIGURE 1 is a side schematic view of a preferred embodiment of an exemplary continuous mining machine according to the present invention;

5           FIGURE 2 is a top plan view of the mining machine of FIGURE 1;

            FIGURE 3 is a side schematic view, with components removed for clarity of illustration, showing the operation of the conveyor chain and angled deck and gathering head of the mining machine of  
10          FIGURES 1 and 2;

            FIGURE 4 is a top plan schematic detail view, with many structures cut away for clarity of illustration, showing the operation of the gathering head of the mining machine of FIGURES 1 through 3;

            FIGURE 5 is a schematic side view showing the use of the  
15          mining machine of FIGURES 1 through 4 in a coal seam and the continuous mining thereof;

            FIGURE 6 is a schematic top longitudinal cross-sectional view of a coal seam that has been mined utilizing the miner of FIGURES 1 through 5 in a novel mining technique;

20          FIGURE 7 is a side view of an exemplary conveyor chain idler sprocket according to an embodiment of the present invention;

            FIGURE 8 is a cross-sectional view of the sprocket of FIGURE 7 taken along lines 8-8 thereof; and

            FIGURE 9 is a side detail schematic view showing exemplary  
25          sprockets for the cutting head for driving the cutting chain for an exemplary machine according to an embodiment of the invention.

### DETAILED DESCRIPTION OF THE DRAWINGS

The basic components of the mining machine 1 according to the present invention are the same as or similar to the components of the machine of U.S. patent 3,874,735. In particular the mining machine 1 includes a chassis 2 supported by conventional crawler tracks 3 and having a front end 2' and a rear end 2". The chassis carries a conveyor shown generally by reference numeral 4 running from the front 2' to the rear 2" including to a tail piece 5 of the chassis 2 mounted by an articulated joint 6. A gathering head 7 is pivoted on the front of the chassis 2 and extends forwardly therefrom for conveying coal to the forward end of the conveyor 4. The conveyor 4 preferably includes a metal trough having the usual side flanges 8 (see FIGURE 2) and a chain 9 with cross bars 10 for carrying material along the conveyor trough. A boom 11 is pivotally mounted on the front end 2' of the chassis 2 generally at 12 (see FIGURE 2) to extend upwardly and forwardly therefrom and is raised up and down by a pair of hydraulic cylinders 13 mounted between the chassis 2 and a portion of the boom 11. A substantially horizontal axis powered cutter head 14 is mounted to the front of the chassis 2', via the boom 11, and electric motors 15 are mounted on the sides of the chassis 2 and are connected to transmissions 16 mounted on the outer sides of the boom 11 by the shafts 17 having a universal joint 18 at at least one end thereof and splined telescopic joints 19. The cutter head 14 is (except for size, as described with respect to FIGURE 9) conventional, as shown in U.S. patent 3,874,735 or as utilized in the CM 245 and CM 285, or any other suitable cutter head, and includes cutter bits 20.

The chain 9 is mounted by a first sprocket 21 (best seen schematically in FIGURE 3) mounted for rotation about a first shaft 22 adjacent the rear 2" of the chassis 2, and a second sprocket 23 (best seen schematically in FIGURES 3 and 4) mounted for rotation about a

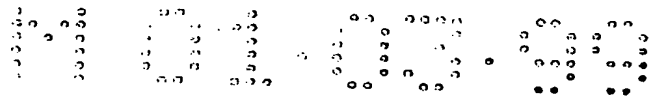

second shaft 24 adjacent the front 2' of the chassis 2 but between the first sprocket 21 and the cutter head 14. The shafts 22, 24 are rotatable about axes generally perpendicular to the dimension of elongation 25 of the chassis 2. Intermediate sprockets 26, 27 (see  
5 FIGURE 3) may be provided as necessary or desirable for properly guiding the chain 9, or the trough with side walls 8 alone may provide the guiding action.

In patent 3,874,735 the chain 9 is powered by motors mounted adjacent the front of the chassis 2, with the front sprocket (comparable  
10 to the sprocket 23 of FIGURES 3 and 4) being the powered sprocket. However that location of the motors is one of the factors of the design of the 3,874,735 patent (and the CM 245 and CM 285 commercial machines implementing that patent) that preclude a reduction in the height thereof. According to the invention, however, this is solved by  
15 utilizing at least one motor 28 (e.g. two motors 28 as seen in FIGURE 2) mounted adjacent the rear 2" of the chassis 2 (past the articulated connection 6). The motors 28 drive the shaft 22 through telescoping and splined transmission shafts 29 (see FIGURE 2) and gear boxes 30, the splined telescoping shafts 29 being preferred in order to allow  
20 articulation of the tail 5 of the chassis 2 about the pivot point 6, e.g. by extending or retracting the hydraulic cylinder 31. A hydraulic pump motor 32 is preferably provided for powering all of the hydraulic components of the machine 1, and the motors 28 may be hydraulic or electric but preferably are electric. Hydraulics are typically used for the  
25 cylinders 13 and 31 and for powering the gathering head up or down as necessary, while electric motors are used for the motors 15 and 28, and for the crawler 3 drives also. The crawler motors are conventional and are inside the crawlers 3.

In operation of the mining machine 1 another conveyor is  
30 provided at the end 2" of the chassis to convey the cut material to the

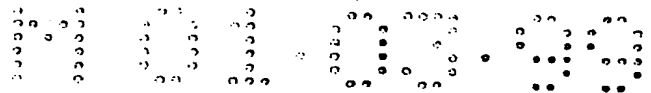

bore mouth. That conveyor -- which is shown only schematically at 33 in FIGURE 5 -- may be any conventional type of conveyor that can be constructed in a size sufficient for use with the mining machine 1, and the particulars of the conveyor 33 are not part of this invention.

5           Since the drive motors 28 for driving the conveyor chain 9 are located adjacent the rear 2" of the chassis 2 rather than at the front adjacent or beneath the gathering head 7, it is possible to reduce the height of the mining machine 1 significantly by making various other changes to the gathering head 7 and components associated  
10 therewith. The gathering head 7 includes first and second counter-rotating discs 35, 36 (see FIGURES 2 and 4) each with upstanding vanes 37, and typically rotating in the directions 38, 39 illustrated in FIGURE 4. An angled deck 40 is substantially coplanar with the discs  
15 35, 36 and is disposed at an angle  $\alpha$  (see the schematic representation in FIGURE 3) with respect to the dimension of elongation 25, and the floor 41 of the bore 42 (see FIGURES 5 and 6) being mined by the machine 1. In the machine of patent 3,874,735, and the commercial embodiments thereof in the CM 245 and CM 285 miners, the angle  $\alpha$  is about 15-16E during normal operation of the machine 1. However  
20 because no motors are present thereat and because the sprocket 23 may be made smaller, that is, the angle  $\alpha$  is a maximum of about 10° during normal operation of the machine 1 according to the present invention, and is typically about 8E or 9E.

          The second sprocket 23, as seen schematically in FIGURES 3  
25 and 4, is made as small as possible while still being able to properly guide the chain 9 as the idler shaft 24 rotates as the chain 9 is powered by the sprocket 21 in the direction of the arrows 43 (see FIGURE 3). Typically the sprocket 23 has a maximum diameter D (see FIGURE 7) of about 20 cm (eight inches), preferably about 18.3-  
30 18.5 cm (7.2-7.3 inches). This is the smallest size feasible if the shaft

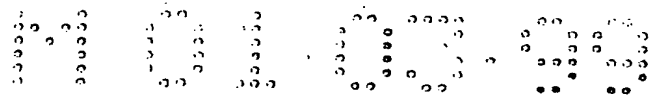

24 is a 7.5 cm (three inch) diameter shaft, while still being able to get the proper horsepower so that the chain 9 is driven to ensure that the coal or other material being cut clears the gathering head 7 and is conveyed away while the machine 1 powered cutting head 14 may be driven at an average radial speed of about 198 meters (650 feet) per minute (which is best for dust control, bit life, and the like). As seen in FIGURE 3 the sprocket 23 is preferably mounted beneath the angled deck 40 so that the coal is moved up by the discs 35, 36 directly onto the trough having the side walls 8 which the conveyor bars 10 traverse. The sprocket 23 preferably has the configuration illustrated in FIGURES 7 and 8, i.e. four teeth 23' with the particularly shaped ends seen in FIGURES 7 and 8, although a three tooth configuration is also feasible.

FIGURE 4 schematically illustrates one exemplary manner in which the counter-rotating discs 35, 36 may be driven. The illustration in FIGURE 4 is essentially the same as that in the 3,874,735 patent, except it being understood that the shaft 24 is an idler shaft which is driven by the chain 9 rotating the sprocket 23 as powered by the motors 28.

Connected to the shaft 24 in the FIGURE 4 embodiment is a transmission element 45 which is operatively connected to the disc 35 for rotating it in the direction 38. In the preferred embodiment the transmission element 45 is a gear, such as in the 3,874,735 patent and the CM 245 and CM 285 machines. The gear 45 cooperates with another gear 46 mounted on a shaft 47, the shaft 47 also including a worm gear 48 which cooperates with a gear 49 on the bottom of the disc 35 to effect rotation thereof in the direction 38. While gears 45, 46, 48, 49 are preferred transmission elements the exact gear construction may be changed depending upon the particular results desired, and other conventional transition elements (such as chains

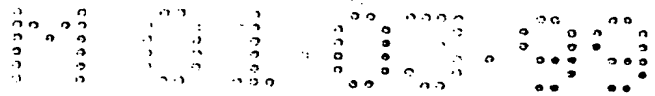

and sprockets, cams and followers, mechanical linkages, and the like.

While not shown in FIGURE 4, the shaft 24 includes another transmission element preferably just like the element 45 at the opposite end thereof for cooperation with the disc 36 to rotate it in the direction 39 in a substantially identical manner.

Details of an exemplary substantially horizontal axis cutting head 14 and transmission element 16 for use with the mining machine 1 according to the invention, to insure that the machine 1 will have an appropriately minimum size while still effectively performing its desired functions, is illustrated in FIGURE 9. For example the drive sprocket 75 (typically two sprockets 75, one for each transmission element 16, are provided adjacent opposite ends of a shaft 76) preferably comprises a five tooth sprocket having a maximum diameter 77 of about 19 cm (7.5 inches) (e. g. the pitch diameter 77 is about 17.8 cm (7.02 inches)) on an about four inch diameter shaft 76, with the cutting chain 79 effective diameter 78 (the trace of the cutting chain bits 20) at that area of about 41 cm (16 inches) or less (e. g. diameter 39 cm (78 is about 15.3 inches)).

The boom 11 may have a stop (not shown) mounted thereon to positively insure that no part (e. g. bits 20) of the cutting chain 79 of the cutter head 14 can come into contact with any part of the gathering head 7. The stop may take the form of a simple block of metal welded or otherwise attached to a part of the boom 11 near the top of the gathering head 7 pan (i. e. angled deck 40), the block dimensioned so that when it engages the pan/deck 40 the cutting chain bits 20 are spaced slightly from all parts of the head 7.

The cutting chain 79 may comprise a conventional cutting chain having alternating connector links 80 and cutting bit links 81 (the links 81 mounting the cutting bits 20), e. g. a Number 73473 clearance chain available from The Cincinnati Mine Machinery Co. of Cincinnati,

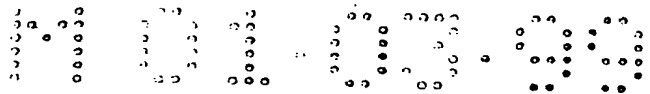

Ohio. The driven sprocket 84 (again two are typically provided, one at either end of shaft 85, and cooperating with a sprocket 75) at the front of the head 14, where the actual cutting is done, may comprise a ten tooth sprocket with a maximum diameter (pitch diameter) of about 36  
5 cm (14 inches) (e. g. about 34 cm (13.35 inches)), and with the cutting head 14 effective diameter a maximum of about 56 cm (twenty two inches) (e. g. about 53 cm (21.04 inches)).

FIGURE 5 schematically illustrates utilization of the mining machine 1 to form a bore 42 including forming a floor 41, a ceiling 51,  
10 and (see FIGURE 6) first and second side walls 52, 53. The machine 1 is typically advanced by powering the crawlers 3 and by moving the cutting head 14, the tail 5, the gathering head 7, and the other components, in essentially the same manner as in U.S. patent 3,874,735, to form the bore 42 by cutting coal from the coal seam 54.

15 The coal seam 54 typically is one having an average thickness of about 1.2 meter (four feet) or less, preferably an average thickness of about .9 meters (three feet) or less, and the machine 1 is ideally suited for coal seams 54 having an average thickness of about .6 meters (two feet) or less. FIGURE 5 schematically illustrates a  
20 machine 1 being used to mine a seam 54 wherein the machine 1 has a chassis height 55 (see FIGURE 1) that is a maximum of about 50 cm (twenty inches), preferably about 48 cm (nineteen inches), while the cutter head 14 has a maximum diameter 56 (see FIGURE 1) of about 56 cm (twenty-two inches), e.g. preferably about 53 cm (twenty-one  
25 inches). The mining machine 1 also preferably has a length 58 (see FIGURE 1) that is small enough to allow the machine 1 to easily negotiate up and down within the seam 54. While the CM 245 has a length of about 33-34 feet, it is preferred that the length 58 of the machine 1 be less than about 9 meters (thirty feet), e.g. about 8.5  
30 meters (twenty-eight feet), or even less.



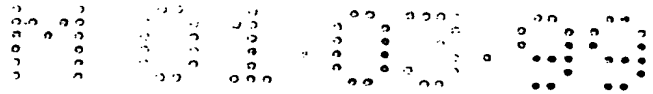

15

FIGURE 5 schematically illustrates use of the machine 1 in a seam 54 that has an average thickness 57 of about twenty-four inches.

The left and right movement of the machine 1 may be controlled using conventional laser beams or the like, but the up and down movement  
5 within the thickness 57 of the seam 54 is preferably controlled as described above.

As schematically illustrated in FIGURE 5, control of the up and down movement of the cutter head 14 (this may not be true up and down with respect to the earth, but up and down with respect to the  
10 thickness of the seam 54) is remotely controlled by a human operator operator at the bore 42 mouth 58 (see FIGURE 6), or at some intermediate location within the bore 42. The human operator typically uses a television monitor 59 as an aid in determining how to control the cutter head 14. The monitor 59 is preferably connected up to at  
15 least a first color video camera 60, and preferably at least a second color video camera 61 is also used. A third color video camera (not shown) may also be utilized, to completely simulate the views that a human operator has when riding and operating conventional continuous miners.

20 The color video cameras 60, 61 may be of any suitable conventional type, such as a Toshiba CCD color camera, model no. IK-M41A, which has internal self-scanning. The cameras 60, 61 also preferably have an internal automatic lens cleaning device, developed by the Bureau of Mines, and known per se. The first video camera 60  
25 is mounted, e.g. on the chassis 2 or associated with the cutter head 14 (e.g. on the boom 11), in a position where it can scan material being cut above the cutter head 14, i.e. at the ceiling 51 of the bore 42 as seen in FIGURE 5. In this way the camera 60 can be used and  
30 utilizable to determine the color of the material being cut. If the cutter head 14 is cutting substantially exclusively within the coal seam 54,

the ceiling 51 will be basically black since there will be at least a small thickness of coal between it and the overlying rock 63. However if the cutter head 14 starts cutting a significant amount of rock 63 the color of the ceiling 51 will change, which can be easily seen by the operator  
5 utilizing the monitor 59, the picture of the ceiling 51 being transmitted by the first camera 60 either by electromagnetic propagations, or through an appropriate cable, to monitor 59.

Similarly the second color video camera 61 is mounted to the chassis 2 or the cutter head (e.g. the boom 11) in a position to scan  
10 the floor 41 cut by the mining machine 1 and utilizable to determine the color thereof. Again if the cutter head 14 is cutting primarily in the seam 54 the floor 41 will be essentially black, whereas if a significant amount of the rock under burden 63 is being cut the color will change and that will be transmitted to the monitor 59.

15 While a single monitor 59 is illustrated in FIGURE 5 it is to be understood that different monitors may be associated with the cameras 60, 61. Alternatively, the images from one of the cameras 60, 61 may be displayed on the monitor 59 at one time while the other is not, the display changing under operator control or periodically, or  
20 an image from each of the cameras 60, 61 may be displayed in different sections of the monitor 59 at the same time. Any appropriate light (or other electromagnetic propagation) source may be utilized to illuminate the area being viewed by one or both of the cameras 60, 61 if necessary or desirable.

25 If a third video camera is provided it points rearwardly of the machine 1 in the bore 42, so that the cameras simulate completely normal viewing positions of the human operator. Alternatively one of the cameras 60, 61 may periodically automatically (or by a human operator at the monitor 59 actuating the control) be moved to a

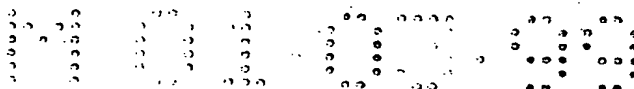

position in which it pointed rearwardly, and then returned to its original position.

The mining machine 1 according to the present invention is typically utilized to form a bore 42 that has a length 65 (see FIGURE 6) of between about 300-600 feet, i.e. much longer than the bore that can be formed by an auger. Also the bore will, of course, have the configuration of the cutter head 14 and the rest of the machine 1, i.e. be substantially rectangular in cross-section rather than circular. While the machine 1 may be utilized merely to form a conventional bore 42 and then be withdrawn, according to the invention it may utilized in another simple but straight-forward method that will allow the mining of additional coal from the seam 54 by a single penetration.

As schematically illustrated in FIGURE 6 (with reference to FIGURE 5 too) the main mine bore 42 is formed having first and second side walls 52, 53, a roof 51, and a floor 41 by powering the crawler tracks 3 and cutter head 14 to move the continuous miner through the mine mouth 58 into the coal seam 54 a depth of more than 150 feet in the direction 66, while the coal in seam 54 is being cut and conveyed toward the mouth 43 using a conveyor 4 and a conveyor 33. Once the desired depth 65 of penetration (which is preferably between about 90-180 meters (300-600 feet)) is reached, the final end wall 67 (see FIGURE 6) having been formed, the miner 1 is retracted (utilizing the crawler tracks 3) a distance in the second direction 68, opposite the penetration direction 66, of greater than about 3 meters (ten feet) e.g. a distance of about 7.5 meters (twenty-five feet). After this retraction a secondary mine bore 69 (see FIGURE 6) is formed by powering the crawler tracks 3 and the cutter head 14 to move the continuous miner 1 into the coal seam 51 through the side wall 52 at an angle  $\beta$  of greater than about  $20^\circ$  and less than about  $80^\circ$  (preferably about  $30-50^\circ$ ) to the first direction 66 for a distance 70

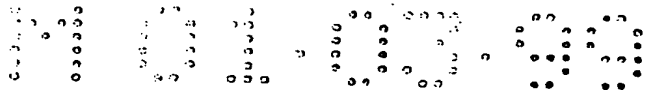

roughly equal to the length 58 of the mining machine 1, while cutting coal and conveying coal toward the mouth using the conveyors 4, 33. Because of the articulated joint 6, and because the conveyors 33 are also mounted in such a way that they are articulated with respect to

5 the machine 1, this turning penetration is possible to form the bore 69, which may also require moving of the cutter head 14 up and down or from side to side slightly initially to effect the necessary penetration of the side wall 52.

After forming the secondary bore 69, the machine 1 is again

10 controlled by the operator to move the crawlers 3 (and the cutter head 14 if necessary) to withdraw from the bore 69 to move back into the main bore 42. The machine 1 is then again retracted a distance in the direction 68 of at least about ten feet from the secondary bore 69, and then the step of forming a secondary bore is repeated. Preferably this

15 is accomplished by penetrating the second side wall 53 to form another secondary bore 71 essentially the same as the bore 69 only penetrating the side wall 53, and again penetrating a distance 70 roughly equal to the length 58 of the machine 1 (e.g. about 20-40 feet). These steps may be repeated as many times as desired preferably

20 alternating between penetration of the first wall 52 and the second wall 53, as schematically illustrated in FIGURE 6, all the way back to the mouth 58.

As yet another alternative to the method described above, after initial formation of the bore 42 the machine 1 may be withdrawn with

25 the cutter head 14 moved upwardly to cut enough extra height so that a human operator may appropriately enter the bore 42. This would typically entail cutting a substantial amount of rock, which would also be conveyed to the mouth 58 and separated from any coal that was cut in a conventional manner. The machine 1 would then enter the

30 already formed and relatively high bore 42 again, with the human

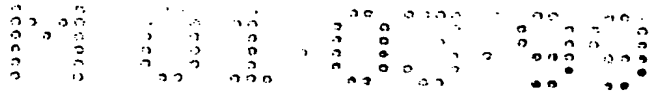

operator behind, and then the human operator would control the machine 1 at specified locations to form the secondary bores 69, 71, as appropriate.

5 It will thus be seen that according to the present invention a mining machine, and a method of utilization thereof, have been provided which provide effective mining of thin coal seams, particularly those having a thickness of about 1.2 meters (four feet) or less, including those having a thickness of about .9 meters (three feet) or less, and even those having a thickness of about .6 meters (two feet)  
10 or less. While the invention has been herein shown and described in what is presently conceived to be the most practical and preferred embodiment thereof it will be apparent to those of ordinary skill in the art that many modifications may be made thereof within the scope of the invention, which scope is to be accorded the broadest  
15 interpretation of the appended claims.

**WHAT IS CLAIMED IS:**

1           1. A continuous mining machine (1) comprising: a chassis (2)  
2 supported by crawler tracks (3), and having a front (2') and a rear (2'')  
3 and elongated in a first dimension (25) between said front and said  
4 rear; a powered substantially horizontal axis cutter head (14) mounted  
5 to said front of said chassis; a conveyor (4) mounted to said chassis  
6 and including an endless conveyor chain (9); said chain connected to  
7 first (21) and second (23) sprockets, said first sprocket mounted for  
8 rotation about a first shaft (22) adjacent said rear of said chassis, and  
9 said second sprocket mounted for rotation about a second shaft (24)  
10 adjacent said front of said chassis but between said first sprocket and  
11 said cutter head; said first and second shafts rotatable about axes  
12 generally perpendicular to said first dimension; and characterized by:  
13           at least one motor (28) mounted adjacent said rear of said  
14 chassis for driving said first shaft to thereby drive said first sprocket  
15 and said conveyor; and further characterized in that wherein said  
16 chassis has a maximum height of about 50 cm and said cutter head  
17 has a maximum effective diameter of about 56 cm.

1           2. A mining machine as recited in claim 1 further characterized  
2 in that said second shaft comprises an idler shaft.

1           3. A mining machine as recited in claim 1 or 2 further  
2 characterized by a gathering head (7) mounted adjacent said front of  
3 said chassis and below said cutter head and at least partly to the rear  
4 of said cutter head, for gathering material cut by said cutter head and  
5 moving the cut material to said conveyor.

1           4. A mining machine as recited in claim 3 further characterized  
2 in that said gathering head comprises a pair of counter-rotating discs  
3 (35, 36) with upstanding vanes (37), and an angled deck (40)  
4 substantially coplanar with said discs; and wherein said second shaft  
5 has first and second transmission elements (45) connected thereto,  
6 said first and second transmission elements operatively connected to  
7 said discs for effecting counter-rotation driving thereof.

1           5. A mining machine as recited in claim 4 further characterized  
2 in that said angled deck during normal operation makes a maximum  
3 angle of about 10° with respect to said dimension of elongation of said  
4 chassis.

1           6. A mining machine as recited in any preceding claim further  
2 characterized in that said cutting head includes a cutting chain drive  
3 sprocket (75) with a maximum diameter of about 18 cm.

1           7. A mining machine as recited in claim 4 or 5 or 6 further  
2 characterized in that said second sprocket has a maximum diameter of  
3 about 20 cm and is mounted beneath said deck.

1           8. A mining machine as recited in claim 7 further characterized  
2 by a plurality of cross bars (10) connected to said chain for moving  
3 conveyed material from said gathering heads to said rear of said  
4 chassis; and further characterized in that said second sprocket  
5 comprises a four tooth sprocket, and said cutting chain drive sprocket  
6 of said cutting head comprises a five tooth sprocket.

1           9. A mining machine as recited in any preceding claim further  
2 characterized by a first color video camera (60) mounted on said  
3 chassis or said cutter head in a position to scan material being cut  
4 above said cutter head and utilizable to determine the color thereof,  
5 said first video camera connected to a monitor (59) to the rear of said  
6 chassis.

1           10. A mining machine as recited in claim 9 wherein said mining  
2 machine forms a floor during operation; and further characterized by a  
3 second color video camera (61) mounted to said chassis or said cutter  
4 head in a position to scan the floor cut by said mining machine and  
5 utilizable to determine the color thereof, said second video camera  
6 connected to said monitor.

1           11. A mining machine as recited in claim 1 further  
2 characterized by a gathering head mounted adjacent said front of said  
3 chassis and below said cutter head and at least partly to the rear of  
4 said cutter head, for gathering material cut by said cutter head and  
5 moving the cut material to said conveyor, said gathering head  
6 comprising a pair of counter-rotating discs with upstanding vanes, and  
7 an angled deck substantially coplanar with said discs;

8           wherein said second shaft has first and second transmission  
9 elements connected thereto, said first and second transmission  
10 elements operatively connected to said discs for effecting counter-  
11 rotation driving thereof;

12           wherein said angled deck during normal operation makes a  
13 maximum angle of about 10° with respect to said dimension of  
14 elongation of said chassis; and



15            wherein said second sprocket has a maximum diameter of  
16        about eight inches and is mounted beneath said deck.

1            12. A mining machine as recited in any preceding claim further  
2        characterized in that said at least one motor comprises two motors,  
3        one on either side of said chassis, and wherein said motors are  
4        operatively connected to said first shaft through splined telescoping  
5        transmission shafts (29), and gear boxes (30).

1            13. A method of mining coal in seams (54) having an average  
2        thickness of less than 1.2 meters using a continuous mining machine  
3        (1) having a chassis (2) mounted by crawler tracks (3), a cutter head  
4        (14) at the front of the chassis, an articulated rear end (2"), a first  
5        conveyor (4) for conveying cut coal from the cutter head to the rear of  
6        the chassis, and a second conveyor (33) operatively associated with  
7        the rear end to convey coal from a bore (42) toward a mouth (58) of  
8        the bore, the continuous miner having a predetermined length from the  
9        cutter head to the rear of the chassis; said method comprising: (a)  
10       forming a main mine bore (42), having first and second side walls, a  
11       roof, and a floor, by powering the crawler tracks and cutter head to  
12       move the continuous miner through the mine mouth into the coal seam  
13       a depth of more than 45 meters in a first direction, while cutting coal  
14       and conveying the coal toward the mouth using the first and second  
15       conveyors; and characterized by the steps of:

16            (b) after the practice of step (a), retracting the continuous miner  
17        a distance of greater than about ten feet; and

18            (c) after the practice of step (b), forming a secondary mine bore  
19        (69) by powering the crawler tracks and the cutter head to move the

20 continuous miner into the coal seam through the main mine bore side  
21 walls at an angle of greater than about 20° and less than about 80° to  
22 the first direction for a distance roughly equal to the predetermined  
23 length of the miner, while cutting coal and conveying cut coal toward  
24 the mouth using the first and second conveyors.

1 14. A method as recited in claim 13 characterized by the further  
2 step (d) of repeating steps (b) and (c) at least once after the practice  
3 thereof.

1 15. A method as recited in claim 14 further characterized in that  
2 step (c) is practiced by moving the miner into contact with the first side  
3 wall of the main bore, and step (d) is practiced first after step (c) by  
4 moving the miner into contact with the second side wall of the main  
5 bore.

1 16. A method as recited in claim 14 or 15 further characterized  
2 in that step (d) is practiced a plurality of times, alternating between  
3 moving the miner into contact with the first side wall of the main bore  
4 and the second side wall of the main bore.

1 17. A method as recited in claim 14, 15 or 16 further  
2 characterized in that the coal seam has an average thickness of about  
3 one meter or less, and steps (c) and (d) are practiced to penetrate the  
4 side walls a distance of between about 6-13 meters in forming each  
5 secondary bore.

1           18. A method as recited in claim 13, 14, 15, 16, or 17 further  
2 characterized in that the coal seam has an average thickness of about  
3 .6 meters or less.

1           19. A method as recited in any of claims 13 - 18 further  
2 characterized in that during the practice of step (a) the miner is  
3 remotely controlled by a human operator, and wherein the miner has  
4 at least a first color video camera (60) mounted thereon; and  
5 characterized by the further step of scanning the roof (51) of the bore  
6 adjacent the cutter head to determine the color thereof, and then the  
7 human operator adjusting, if necessary, the position of the cutter head  
8 and the vertical orientation of the miner in response to that scanning.

1           20. A method as recited in claim 19 further characterized in that  
2 wherein the miner has a second color video camera (61) mounted  
3 thereon; and characterized by the further step of scanning the floor  
4 (41) of the bore with the second video camera to determine the color  
5 thereof, and then the human operator adjusting, if necessary, the  
6 position of the cutter head and the vertical orientation of the miner in  
7 response to that scanning.

1           21. A method as recited in any of claims 13 - 20 further  
2 characterized in that step (a) is practiced to penetrate the coal seam a  
3 distance of between about 90-180 meters.

1           22. A method as recited in any of claims 14 - 16 and 18 - 21  
2 further characterized in that steps (c) and (d) are practiced to

3 penetrate the coal seam a distance of between about 6-13 meters in  
4 forming each secondary bore.

1           23. A continuous mining machine as recited in claim 1 further  
2 characterized by: a gathering head (27) mounted adjacent said front  
3 of said chassis and below said cutter head and at least partly to the  
4 rear of said cutter head, for gathering material cut by said cutter head  
5 and moving the cut material to said conveyor, said gathering head  
6 comprises a pair of counter-rotating discs (35, 36) with upstanding  
7 vanes (37), and an angled deck (40) substantially coplanar with said  
8 disc;

9           said second shaft having first and second transmission  
10 elements (45) connected thereto, said first and second transmission  
11 elements operatively connected to said discs for effecting counter-  
12 rotation driving thereof;

13           said angled deck during normal operation making a maximum  
14 angle of about 10° with respect to said dimension of elongation of said  
15 chassis; and

16           said chassis having a maximum height of about 50 cm; and said  
17 cutter head having a maximum diameter of about 56 cm.

1           24. A mining machine as recited in claim 23 further  
2 characterized in that said second sprocket has a maximum diameter of  
3 about 20 cm and is mounted beneath said deck.

1           25. A mining machine as recited in claim 23 or 24 further  
2 characterized in that said cutting head includes a cutting chain drive  
3 sprocket (75) with a maximum diameter of about 18 cm.

- 1           26. A mining machine as recited in claim 25 further
- 2     characterized in that said second sprocket comprises a four tooth
- 3     sprocket, and said cutting chain drive sprocket of said cutting head
- 4     comprises a five tooth sprocket.

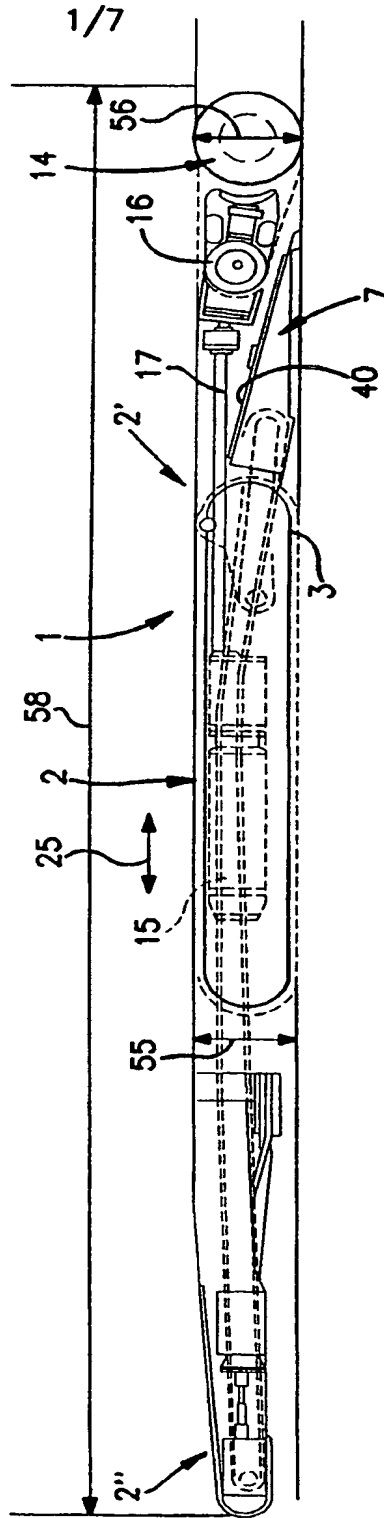

FIG. 1

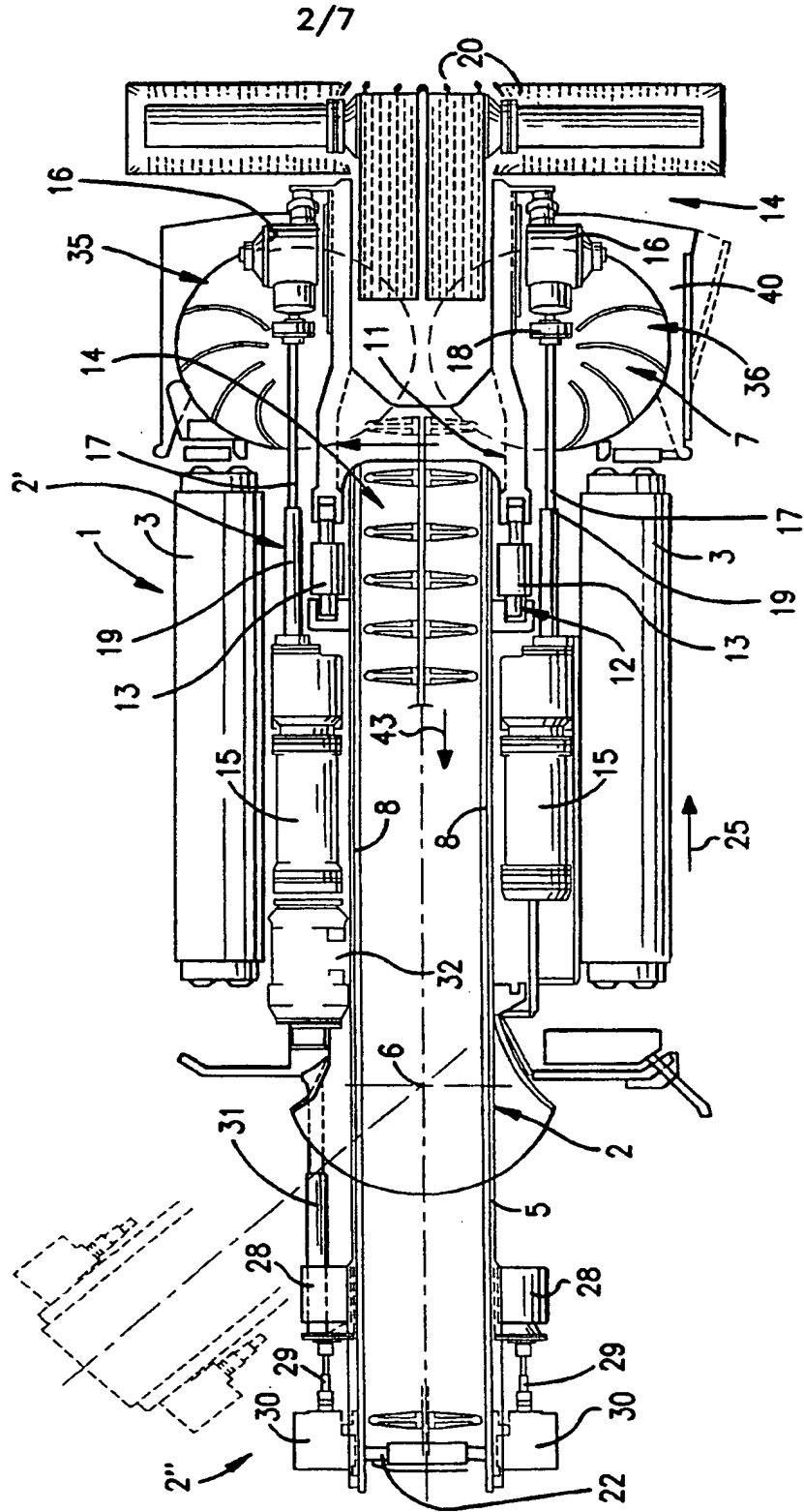

FIG. 2

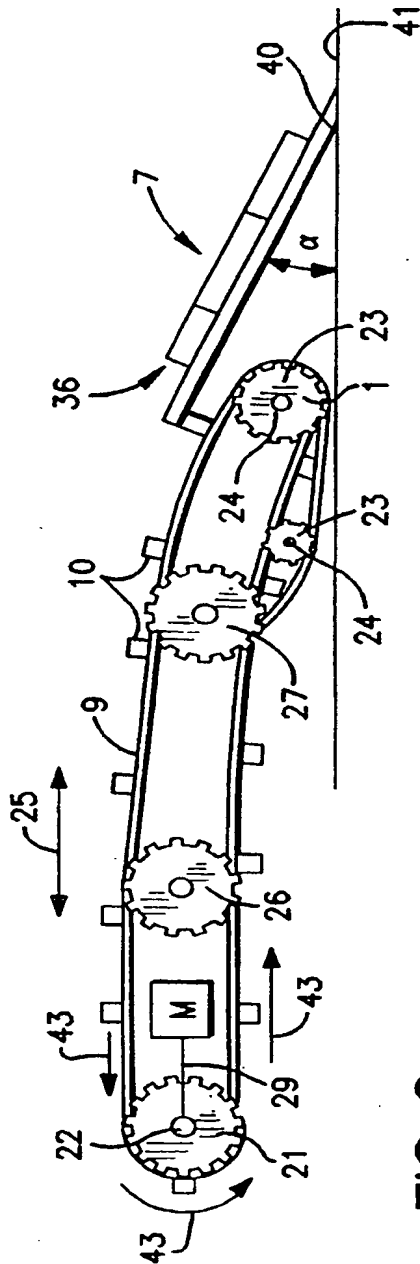

FIG. 3

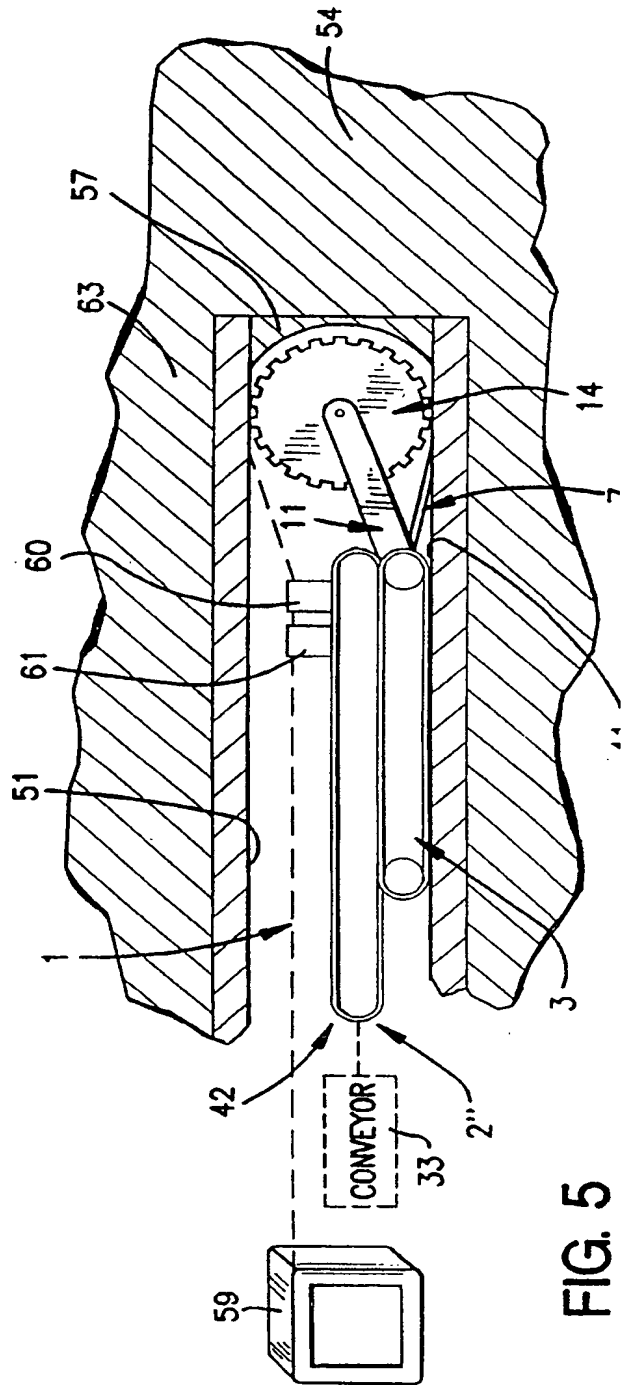

FIG. 5



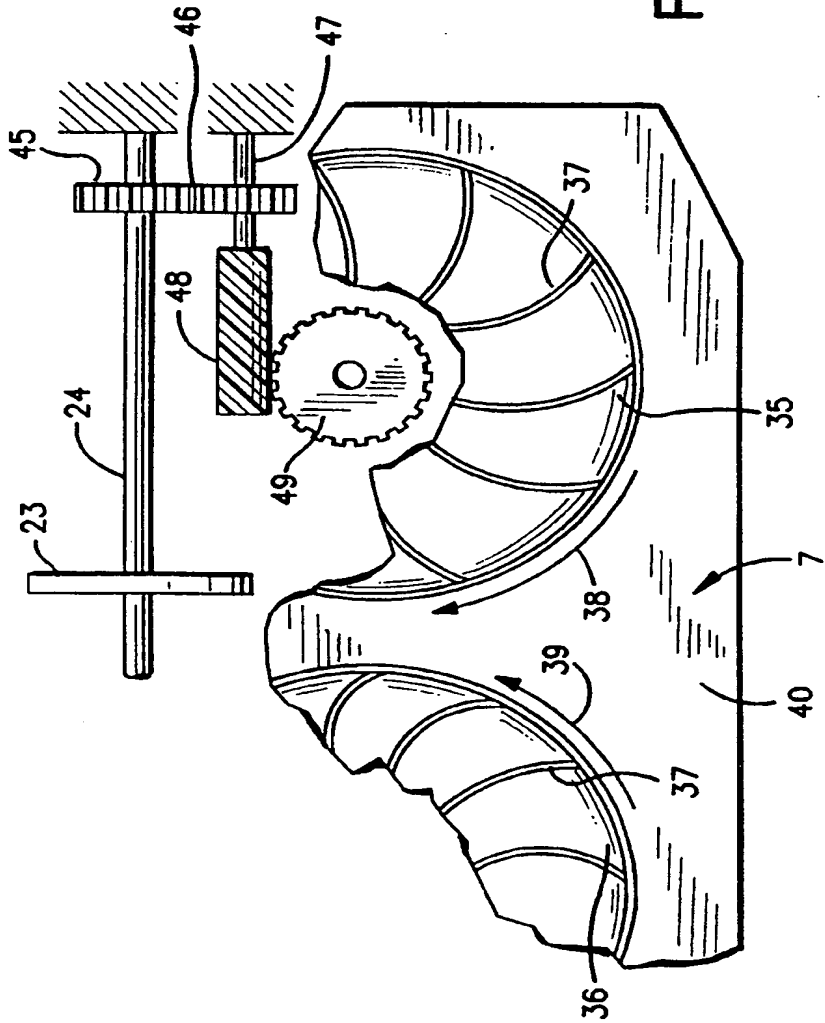

FIG. 4

5/7

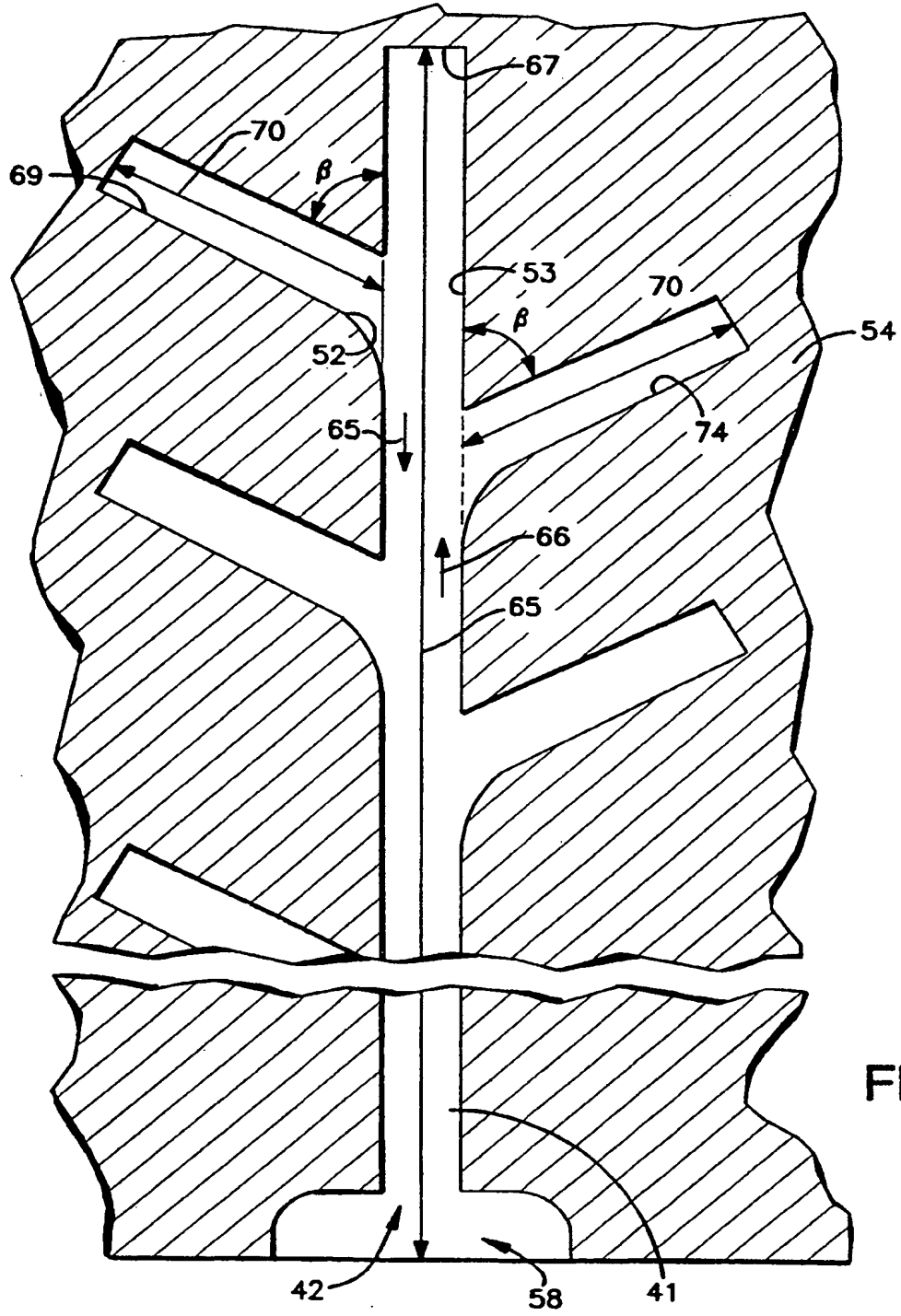

FIG. 6

FIG. 8

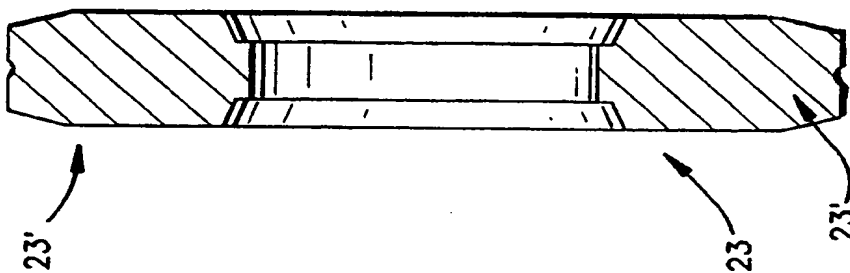

FIG. 7

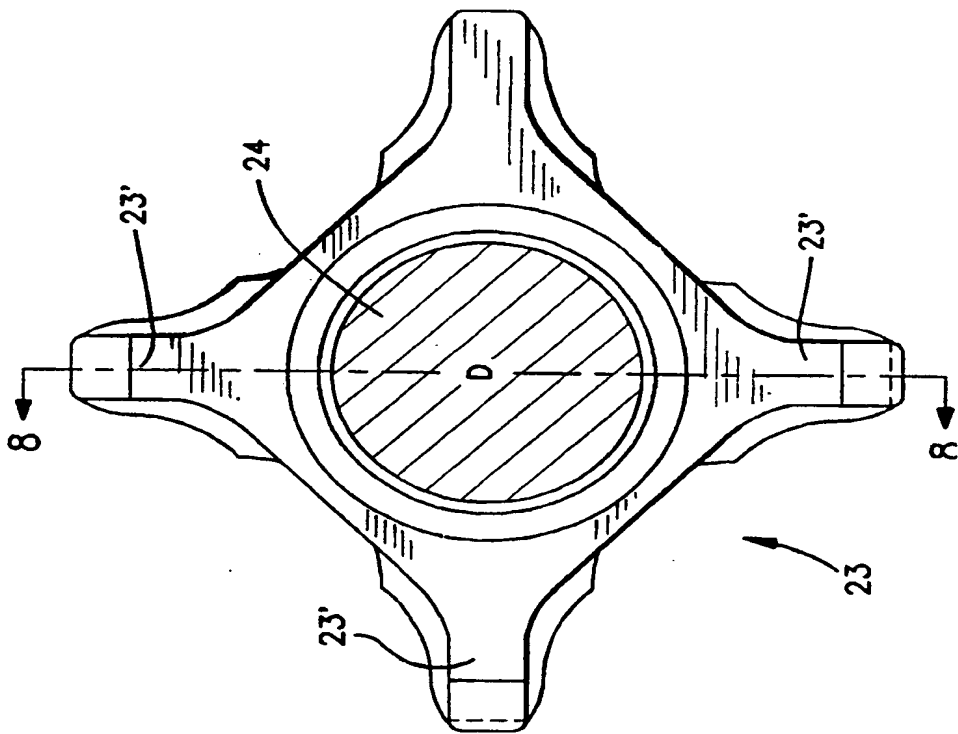
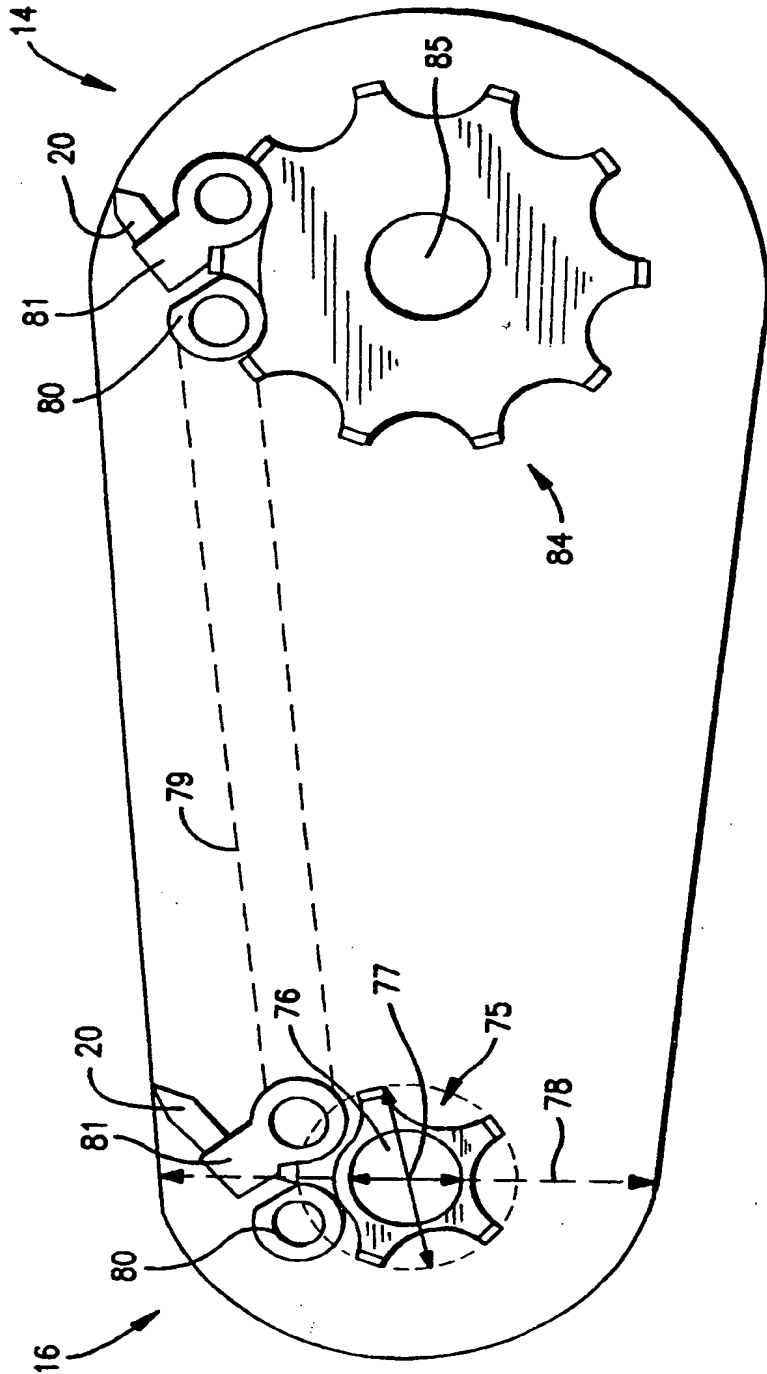

FIG. 9



PTO-1449		Application No.		Applicant(s)					
Information Disclosure Citation in an Application		Docket Number 067083		Group Art Unit		Filing Date			
		U.S. PATENT DOCUMENTS							
		DOCUMENT NO.	DATE	NAME	CLASS	SUBCLASS	FILING DATE		
	A	1,488,106	03/25/1924	J. J. Fitzpatrick	N/A	N/A	02/05/1923		
	B	4,333,539	06/08/1992	Lyons et al.	175	61	12/31/1979		
	C	5,411,088	05/02/1995	LeBlanc et al.	166	265	08/06/1993		
	D	5,653,286	08/05/1997	McCoy et al.	166	105.5	05/12/1995		
	E	5,775,433	07/07/1998	Hammett et al.	166	98	04/03/1996		
	F	6,179,054	01/30/2001	Stewart	166	105.5	07/31/1998		
	G	6,357,530	03/19/2002	Kennedy et al.	166	369	09/27/1999		
FOREIGN PATENT DOCUMENTS									
		DOCUMENT NO.	DATE	COUNTRY	CLASS	SUB	TRANSLATIO N		
							YES	NO	
	H	SU-1448078-A1	03/25/1987	Russia	E21F	5/00-F 7/00	X		
	I	SU-1770570-A1	03/30/1990	Russia	E21F	7/00	X		
	J	SU-750108	06/26/1975	Russia	E21C	45/00	X		
	K	WO 98/35133	08/13/1998	PCT	E21C	27/24	X		
	L	WO 01/44620	06/21/2001	PCT	E21B	43/38	X		
	M	GB 2 255 033	10/28/1992	Great Britain	B04B	11/02	X		
	N	CA 2 278 735	01/13/1998	Canada	E21C	21/24	X		
NON-PATENT DOCUMENTS									
		DOCUMENT (Including Author, Title, Source, and Pertinent Pages)					DATE		
	O	Notification of Transmittal of the International Search Report or the Declaration (PCT Rule 44.1) mailed February 27, 2004 (9 pages) re International Application No. PCT/US 03/30126.					09/23/2003		
	P	Fletcher, "Anadarko Cuts Gas Route Under Canadian River Gorge," Oil and Gas Journal, pp. 28-30					January 25, 2004		
	Q	Kalinin, et al., "Drilling Inclined and Horizontal Well Bores," Nedra Publishers, Moscow, 1997, 15 pages					1997		
	R	Arens, V.Zh., "Well-Drilling Recovery of Minerals," Geotechnology, Nedra Publishers, Moscow, 7 pages, 1986					1986		
EXAMINER					DATE CONSIDERED				
EXAMINER: Initial if citation considered, whether or not citation is in conformance with MPEP § 609. Draw line through citation if not in conformance and not considered. Include copy of this form with next communication to the applicant.									

U.S. Patent and Trademark Office